

SELF FLASHING STEEL ACCESS HATCH



**ARCHITECTURAL
SPECIALTIES INC.**

Specifications: Furnish roof access hatches model (specify) as manufactured by ARCHITECTURAL SPECIALTIES, INC. unit shall withstand 50 pounds per square foot live load.

The unit is to be constructed of steel. Door and curb base corners shall be mitered and fully welded and equipped with integral metal cap flashing for weathertight installation. Door shall be equipped with 1" insulation between panel and liner and a neoprene gasket seal. Curb base insulation shall be 1/2" rigid insulation.

Unit shall be equipped with inside locking handle and pad lock hasp, and a compression-operated shock absorbing cylindrical spring. All hardware shall be plated. Factory finish shall be red oxide primed. Installation shall be in accordance with manufacturer's instructions.

* The hatch door hinges on short side

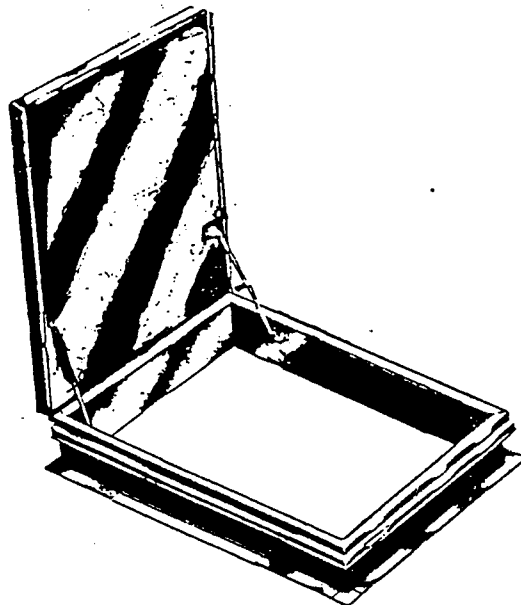

Description:

CURB BASE

14 gauge steel with integral metal cap flashing.

3" nail flange to secure to roof deck.

DOOR SEAL

Neoprene gasket.

INSULATION

1" thick insulation between door panel and liner.

1/2" rigid insulation surrounding base.

HINGES

noncorrosive 3" hinges with non-removable pins.

LINKAGE

10 gauge steel automatically locking stop arm for opening and closing lid.

LID

14 gauge galvanized steel.

LATCH

Tapered, inside locking handle with interior padlock

COMPRESSION ROD

Compression operated, shock absorbing cylinder:

FINISH

SH Models - Red oxide primed

Other coatings available at additional cost.

CLEAR OPENING

2'6" x 3'0", 2'6" x 4'6", 2'6" x 5'0", 3'0" x 3'0"

3'0" x 4'0", 4'0" x 4'0"

SIZES

Width x Length, Rough opening

FILL IN	
QUANTITY	SIZE

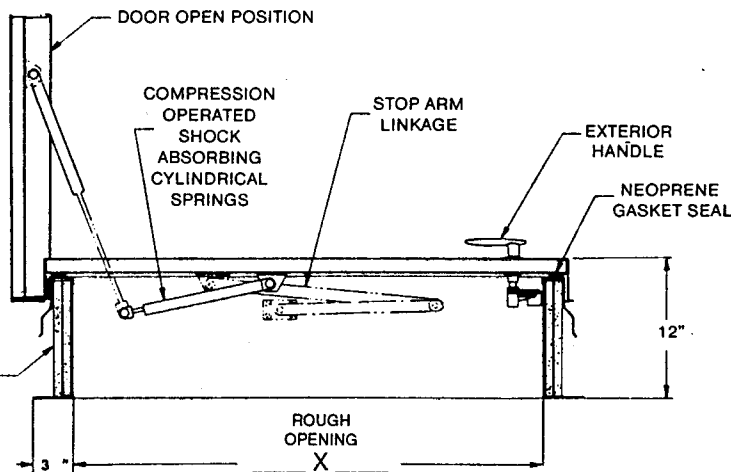

PROJECT _____ CONTRACTOR _____

ADDRESS _____ ARCHITECT _____

CITY/STATE _____ DATE _____



**ARCHITECTURAL
SPECIALTIES INC.**

P.O. BOX 22325 PHONE (503) 232-2966
PORTLAND, OR 97222 FAX (503) 232-4028

DISTRIBUTED BY: