



SURROUND SAFETY RAIL

Roof Hatch Accessory with Gate & Latch

SPECIFICATION: Surround Safety Railing as manufactured by ARCHITECTURAL SPECIALTIES, INC. of Portland, Oregon is a railing system specifically for use on ASI Roof Hatches for safety precautions. The unit is to be constructed of brackets welded on ASI Roof Hatch and uprights welded on brackets for a secure installation. Standard factory black prime finish with bright safety labels, factory applied. Some assembly may be required on site. Safety Railing System Meets OSHA Standard CPR 29 1910.23 and CPR 29 1910.27. Rails engineered to meet or exceed the following: resist a concentrated load of 200 pounds or a linear load of 50 pounds per linear foot per 2014 OSSC 1607.8.1.1

RAIL / POST: 1-1/4" ID, GPE Sched. 40 A53A Grade B seamed steel with plastic caps. Brackets welded to roof hatch

GATE SYSTEM: 1/4"x2" Steel flat bar, self-closing, gate latch, steel hinge(s).

RAILING CLAMPS: Hand rail cross over fittings for 1-1/4" pipe.

INSTALLATION: Post and rails to be assembled on site by purchaser or factory installed. Fasteners are included.

WARRANTY: 5 year manufacturer's parts only warranty from shipping date.

SPECIAL NOTES: Unit is not to be used as a hoisting mechanism and/or as a safety tie off and will void warranty.

ROOF HATCH SIZE (In Inches):

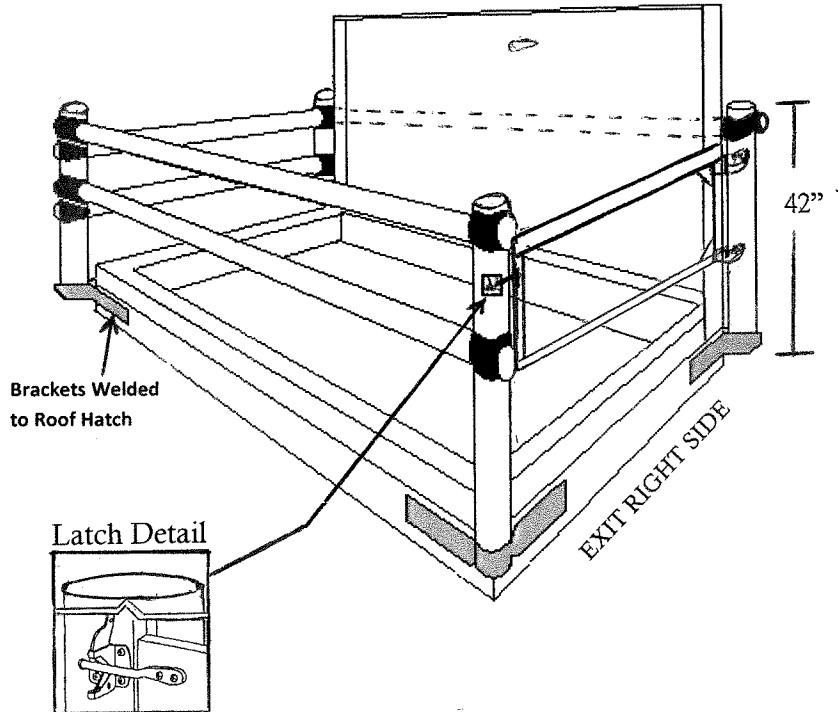

PLEASE CIRCLE GATE EXIT SIDE BELOW (RIGHT or LEFT).

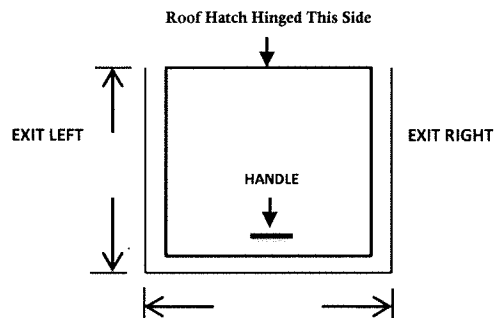

Contractor:	Project Name:
Architect:	Project Address:
Date:	City/State: